

INKONGWENI RIVER BANK PROTECTION
MARGATE, SOUTH COAST, KZN

HYDRAULIC & EROSION CONTROL / RIVER BANK PROTECTION

Product: Gabions & Reno Mattresses

Problem

The residents of Santana Flats, a multi-storey development on the Margate beachfront that lies adjacent to the Inkongweni River on the KwaZulu-Natal South Coast, were concerned that the deterioration of the riverbank would cause instability to their buildings foundation.

Evidence suggested that the erosion was caused by the strong flow of the water in the river.

Solution

The solution entailed the construction of a 2m high gabion structure resting on a 300mm thick Reno mattress spanning a total length of 160m. The mattress extended in front of the structure for a further 2,5m thus forming an apron to protect the superstructure from scour. In addition, a mattress revetment with a width of 2m was constructed on the slope behind the superstructure to protect the embankment during high flows.

The structure was constructed with PVC coated mesh and this will considerably increase the design life and durability of the structure.

Benefits

PVC coated mesh used in the structure provided for an economical, yet durable solution.

The labour intensive nature of gabion construction allowed for employment of local labourers.

The flexibility of the Reno mattress apron allows for settlements and will prevent undermining of the base of the structure should scour occur.

Since gabions are environmentally friendly, the structure blends into the surroundings in the serene seaside town of Margate.



During construction

Date: Jul 2000



Immediately after construction

Date: Sep 2000



After construction

Date: Dec 2000

Client name:

MARGATE TLC

Main contractor name:

MARGATE ASPHALT

Consultant:

KANTEY & TEMPLAR

Product used:

GABIONS, RENO MATTRESSES

Construction info:

Construction date:	JULY 2000
--------------------	-----------

Completion date:	AUGUST 2000
------------------	-------------

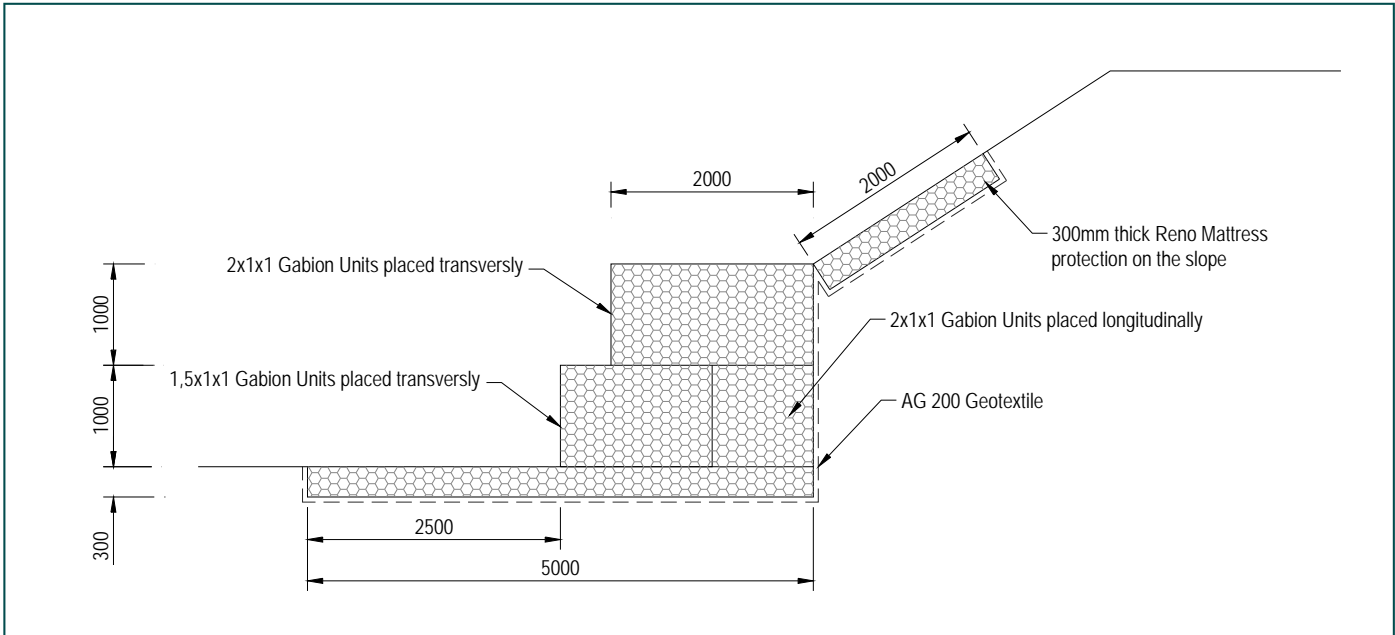

Typical Section

Maccaferri SA (Pty) Ltd

HEAD OFFICE - DURBAN, SOUTH AFRICA
P O Box 15777, Westmead, 3608 Tel: +27-31-700 8456 Fax: +27-31-700 8469 e-mail: dbnsales@maccaferri.co.za

JOHANNESBURG, SOUTH AFRICA
P O Box 2285, North Riding, 2162 Tel: +27-11-704 0160 Fax: +27-11-704 0159 e-mail: jhbsales@maccaferri.co.za

CAPE TOWN, SOUTH AFRICA
P O Box 22150, Fish Hoek, 7974 Tel: +27-21-702 1416 Fax: +27-21-702 2977 e-mail: cptsales@maccaferri.co.za

MADAGASCAR
BP 168 Antananarivo 101, Madagascar Tel: +261-20-22-231 02 Fax: +261-20-22-553 90 e-mail: maccaferri@moov.mg

www.maccaferri.co.za

